

Clinical Centrifuges

SeroSpin

Clinical Centrifuge

SeroSpin

- Recommended for cross matching test in blood banks
- Specifically designed, light polycarbonate rotor
- Optional rotor with tube tightening spring
- Smooth operation with motorized lid opening and closure
- Compact, light-weighted, and ergonomic design
- Unique air cooling structure, perfect for heavily routine works
- Easy to clean specially coated glossy surface and stainless chamber



Technical Specifications

		SeroSpin*
Speed	Max. RPM / Fixed angle	3,400 rpm
RCF (xg)	Max. RCF / Fixed angle	1,118 xg
Max. capacity / Fixed angle		12 x 5mL(L 75 mm) tube
ACC/DEC	ACC/DEC ramps	5 / 6 steps
	Acc. time to max. speed	14 / 38 sec
	Dec. time from max. speed	13 / 37 sec
Time control		< 100 min, pulse, continuous
Program memory		10
Noise level		< 60 dB
Imbalance cutoff		Yes
Dimension (W x D x H, mm)		293 x 380 x 242 mm
Weight without rotor		15 kg
Power consumption		200 VA
Power supply (V/Hz)		210~240 V, 50 / 60 Hz (110 V optional)
Cat. No.		SE

* Registered as medical device at MFDS¹⁾

¹⁾ MFDS : Ministry of Food and Drug Safety (KOREA)

Fixed Angle Rotor for SeroSpin

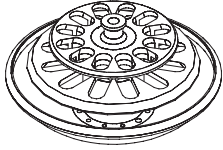
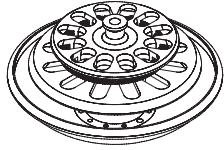
Rotor		Tube Capacity	Max. RPM (rpm) Max. RCF (xg)
A-sero-12(A) 	A-sero-12(B) Incl. a spring holder 	12 x 75 mm tube	3,400 1,118
Type : Angle Rotor Max. Capacity : 12 x 5 mL Size (ø x H) : ø173 x 87.5 mm Radius : 86.5 mm			

* Radius : From the center of the rotor to the inner end of tube carrier.